

# **Sleep Apnea Therapeutic Device - Auto CPAP**

## **User Manual**

**--- Colour Screen**

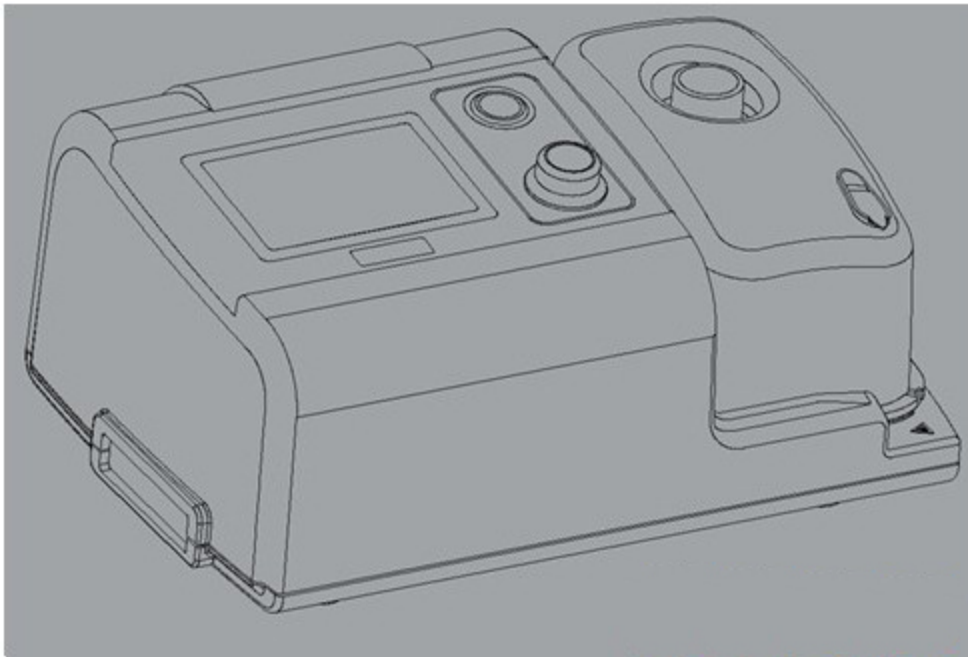

Please read it carefully before using this product.

Dear Customer:

Thank you for choosing our Auto CPAP (continuous positive airway pressure). This device could treat or relieve respiratory disease by nasal continuous positive airway pressure therapy. We sincerely hope that this device bring you health and happiness. Please feel free to contact us if you have any suggestions or dissatisfaction about the device.

*Please read the user manual before operating this device. If you have any questions concerning the use of this device, contact your home care provider or health care professional.*

# Contents

|   |           |
|---|-----------|
| <b>1. Introduction .....</b>  | <b>1</b>  |
| 1.1 Intended Use .....  | 1         |
| 1.2 Applicable Scope .....  | 1         |
| 1.3 Warnings, Cautions and Contraindications .....                    | 1         |
| 1.3.1 Warnings .....  | 1         |
| 1.3.2 Cautions.....   | 3         |
| 1.3.3 Contraindications .....   | 4         |
| 1.4 Device Components.....  | 5         |
| 1.5 List of Terms.....  | 6         |
| 1.6 List of Symbols.....  | 6         |
| <b>2. Features .....</b>  | <b>7</b>  |
| 2.1 Buttons .....   | 7         |
| 2.2 TFT Display .....   | 7         |
| 2.3 Power Adapter, Power Port, Data Port, USB Port and USB Cable..... | 7         |
| 2.4 Humidifier Function .....   | 8         |
| 2.5 Power Outage Alarm .....  | 8         |
| 2.6 Interface .....   | 8         |
| 2.6.1 Main Interface and Sub-interface.....                           | 8         |
| 2.6.2 Interface Icons .....   | 11        |
| 2.6.3 Parameter Instruction .....                                     | 12        |
| 2.6.4 Parameter Setting .....   | 13        |
| <b>3. Device Operation .....</b>                                      | <b>15</b> |
| 3.1 Device Checking and Connection.....                               | 15        |
| 3.2 Humidifier Setting .....  | 17        |
| 3.3 Turn on/off Device.....   | 17        |
| <b>4. Routine Maintenance .....</b>                                   | <b>18</b> |
| 4.1 Host Cleaning .....   | 18        |
| 4.2 Water Chamber Cleaning.....                                       | 18        |
| 4.3 Tubing Cleaning .....   | 18        |
| 4.4 Mask Cleaning .....   | 18        |
| 4.5 Filter Cleaning .....   | 19        |
| 4.6 Disinfection.....   | 19        |
| 4.7 Transferring to Another Patient .....                             | 19        |
| <b>5. Troubleshooting.....</b>  | <b>19</b> |
| <b>6. Waste Disposal.....</b>   | <b>21</b> |
| <b>7. Warranty .....</b>  | <b>21</b> |
| <b>8. Packing List .....</b>  | <b>21</b> |
| <b>9. EMC Requirements.....</b>                                       | <b>22</b> |

# **1. Introduction**

## **1.1 Intended Use**

The automatic sleep apnea therapeutic device Auto CPAP in our company is mainly used for treatment of obstructive sleep apnea-hypopnea syndrome (OSAHS) in the clinical and at home. It is to be used only under the instruction of a licensed health care professional.

This Device can provide a continuous positive airway pressure. The professionals set a corresponding airway pressure according to users' sleeping apnea degree to provide the treatment.

The device has 2 working mode CPAP and Auto CPAP, when the device is set to Auto CPAP, the device will track every breath during sleep, automatically adjust a proper output pressure for user to make a comfort treatment; While the device is set to CPAP mode, then the machine will run at the preset fixed pressure.

The humidifier cooperates with the host to provide the user with the air of suitable temperature and humidity to avoid drying of user's nasal mucosa and make comfort treatment. The host controls the humidifier's turning on/off, the principle of which is to heat the water in the chamber and make the air inhaled by the user with suitable temperature and humidity.

## **1.2 Applicable Scope**

Auto CPAP is mainly suitable for adult OSAHS patient and is not suitable for children or the user with the physical, sensual or intellectual disability without assistance or supervision.

## **1.3 Warnings, Cautions and Contraindications**

### **1.3.1 Warnings**

Warnings indicate the possibility of injuries to the user or operator, please read it carefully before using it.

- The Instructions is for reference. It cannot supersede the professional medical's guidance for the use of the device.
- The device is not suitable for life support.
- All accessories of the device can only be recommended by the manufacturer or related professionals.
- The device may be interfered under the following operating environment:
  - The electromagnetic fields exceed 3V/m under the EN60601-1-2 test

conditions.

- Operating high frequency device (diathermy).
- (Electric shock) defibrillator, or short-wave therapeutic device.
- Radiation (Such as x-ray, CT).
- Electromagnetic field (Such as MRI).
- Do not wear the mask until the device is running normally.
- Keep the device dry,tubing and mask exhalation port smooth before running.
- The devices has the possibility to allow re-breathing of exhaled air,to avoid this problem please follow the below suggestions:
  - Using the tubing of the device manufacturer.
  - Do not wear the mask for a long time if the machine stop working.
  - Do not block or attempt to block the leaking joints.
- This device is not recommend to use with the oxygen to avoid fire hazard.
- Do not use the device in the environment with flammable anesthetic mixture,oxygen,air or the nitrous oxide.
- Keep away from toxic or hazardous steam during the operation.
- Do not use the device when the room temperature is higher than 35°C, otherwise the air flow temperature may be higher than 41°C, which will cause airway irritation or damage.
- Do not use this device under direct sunlight or near the heating equipment, otherwise it will increase the temperature of the output air.
- Regularly check the power cable, if there is any damage,stop using and replace it.
- Disconnect the power plug before cleaning the device to avoid electric shock. Do not immerse the device in any liquid.
- Place the host in a position lower than the mask when using the device to prevent the condensed water in the tubing flowing into the user nasal,causing suffocation.
- If the humidifier leaks or is damaged, do not use the device. It cannot be continued to use until the damaged part being replaced.
- Do not touch the heater plate before it cools down after disconnecting the

power supply.

- Do not add the water with a temperature above 35°C.
- Do not splash the water into the device when installing the water chamber.
- If you notice any damage of the device or any unexplained performances such as unusual harsh sounds, please disconnect the power supply, empty the water in the chamber and stop using the device. Then contact your home care provider or the manufacturer.
- All the maintenance should be done by the manufacturer or its authorized personnel or it may cause the injury, voidness of warranty or significant economic losses.

### **1.3.2 Cautions**

Cautions indicate it may damage the device, please read it carefully.

- Do not wear the mask until the device is running normally.
- Do not operate the device beyond the range of non-operating temperature. If the device was exposed at a too-high or too-low temperature previously, make it return to the room temperature before use.
- Do not immerse the device in any liquid, or let any liquid enter into the device or the filter at the air inlet.
- The condensed water may damage the device. Make sure the device reach the room temperature before use.
- A properly good fitted filter is required during the normal running.
- The tar generated by smoking gathering on the device shell will lead to device failure.
- If any liquid splashes on the heater plate, disconnect the power supply, use it until it get completely dry.
- Take preventive measures to avoid device damages due to water.
- Only the distilled or pure water can be used in the water chamber. Other liquid may damage the humidifier and device, even endanger the user.
- Do not exceed the maximum water level marked on the water chamber.
- Do not splash the water into the device when installing the water chamber.
- Do not tilt the device to avoid the water flowing back into the device. If it happens, please disconnect the power and stop using it.

### 1.3.3 Contraindications

Clinicians should know the device can provide a pressure up to 20cm H<sub>2</sub>O, when evaluating relative risks and benefits of using the device. In case of any single fault, the max pressure should not be more than 30cm H<sub>2</sub>O. Studies have shown that some patients with the following circumstances may not be suitable for the treatment of this device.

- Bullous lung disease
- Pneumothorax
- Pneumomediastinum
- Serious lack of effective circulating blood volume with shock
- The one in a coma or disturbance of consciousness and unable to cooperate with or accept the mask treatment
- Lots of respiratory secretions and coughing, weak breathing independently
- Pathological hypotension
- Pneumothorax when using nasal continuous positive airway pressure.

Be careful when making prescriptions for the following susceptible patients with the treatment of the sleep apnea therapeutic device: cerebrospinal fluid (CSF) leakage, cribriform plate malformation, brain trauma history and / or pneumothorax. (Chest 1989;96:1425-1426)

Those with symptoms of sinusitis or otitis media is not suitable to adopt the positive airway pressure therapy. The patient with upper airway obstruction and the alcoholics is also not suitable to adopt the positive airway pressure therapy. In case of any questions about the treatment, please contact your doctor.

## 1.4 Device Components

### • Device Components

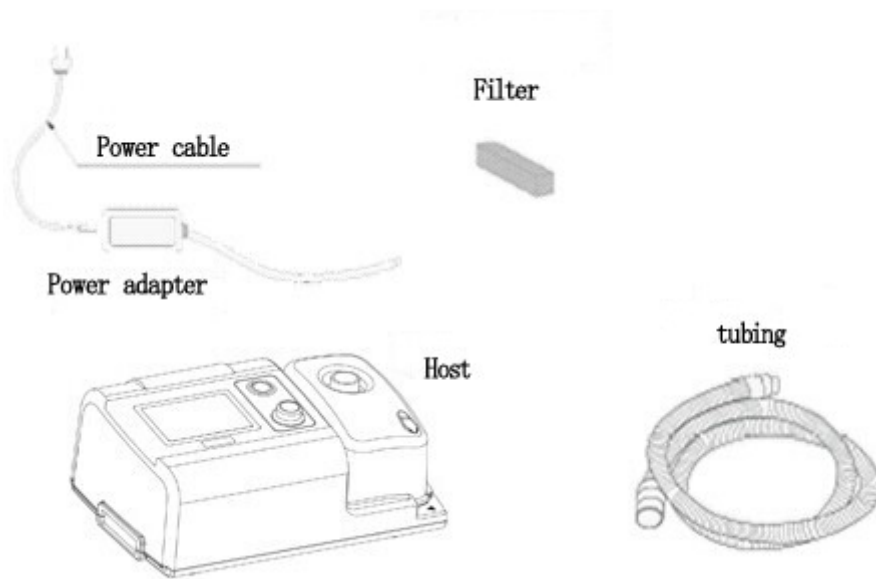

Fig.1-1 Device Components

### • Host Composition

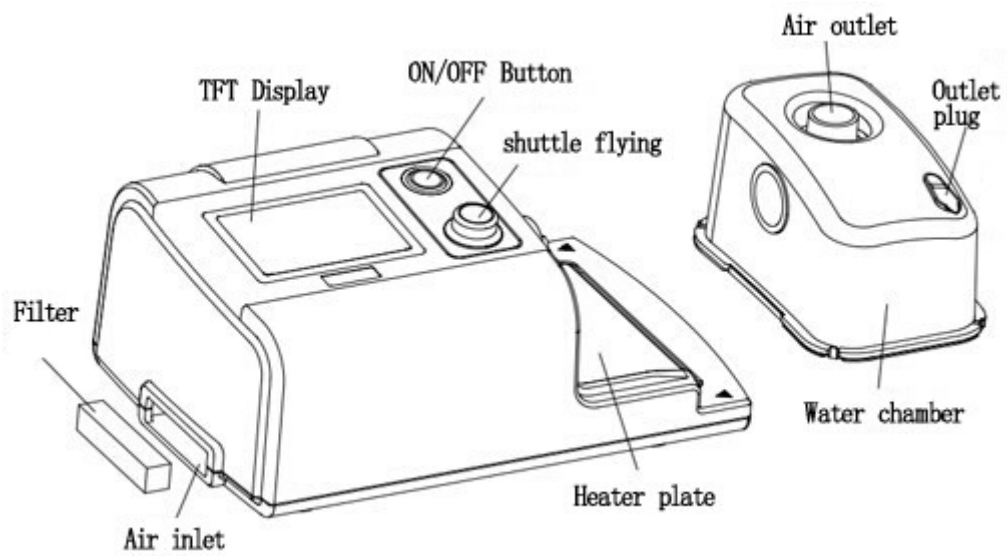

Fig. 1-2 Front Panel of Host



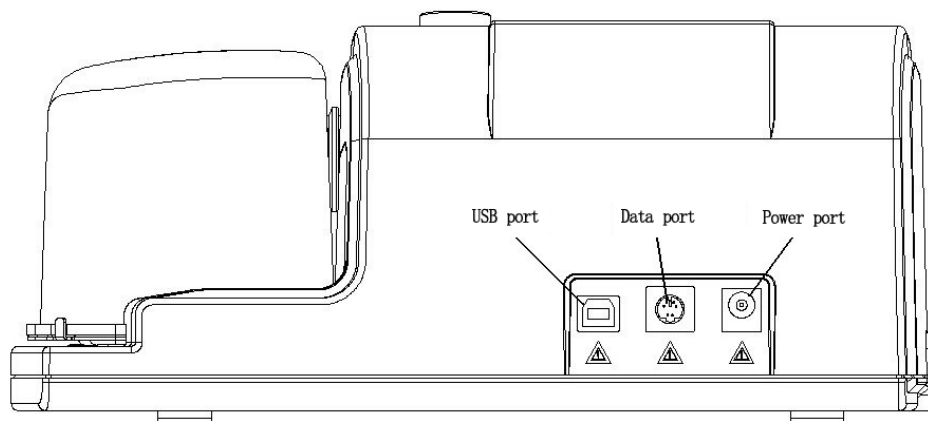

Fig.1-3 Back Panel of Host





## 1.5 List of Terms

Terms and abbreviations in the Instructions are as follows:

| Term/Abbreviation | Definition  |
|-------------------|---|
| Shuttle flying    | Able to be rotated clockwise or counterclockwise and be pressed.  |
| ON/OFF button     | Enable the device in a booting or standby state.  |
| Booting state     | The host motor works; the humidifier works as set by the user. The device turns to the state of providing fresh air for the user. |
| Standby state     | The host motor stops working. If the humidifier is on, turn it off.   |

## 1.6 List of Symbols

The symbols on the device as follows:

| Symbol  | Definition  |
|---|---|
|  | Type BF applied part  |
|  | Class II (double insulation)  |
|  | Caution   |
| <b>IPX1</b>   | Degree of Protection Against Ingress of Water   |
|  | Conform to the Waste Electrical and Electronic Equipment /the Restriction of the Use of Certain Hazardous Substances in Electrical and Electronic Equipment |
|  | Warning for hot   |

The symbol in the Instructions as follows:

| Symbol  | Definition         |
|---|--------------------|
|  | Warnings, cautions |

## 2. Features

### 2.1 Buttons

1. ON/OFF button: It may turn on or off the device and close alarms. If the device is connected to the power, the ON/OFF button indicator will be on.

2. Shuttle flying: It can be rotated clockwise/counterclockwise or be pressed. When it is rotated clockwise, it may move to the next settings on the current interface or enlarge the parameter or come to the next parameter. When it is rotated counterclockwise, it may move to the previous focus on the current interface or diminish the parameter or come to the previous parameter. Press the shuttle flying, it may perform the functions indicated by the current focus, or enter / edit the interface/confirm

⚠ Do not remove the shuttle cap. The metal rod in the shuttle may contact the external current, resulting in the damage of the host. If the shuttle cap falls off, you may contact the dealer or us to purchase a new shuttle cap.

⚠ In case of the button failure, you may contact the dealer or us for help.

⚠ Press any button to activate the screen backlight, if screen backlight is turned off. This press will not cause any operation.

### 2.2 TFT Display

A 3.5-inch TFT display is adopted to mainly display the current parameters and states for the user and operator. Please refer to Chapter 3 Device Operation for more interface operation.

⚠ If the display does not work normally, please contact us or the dealer.

### 2.3 Power Adapter, Power Port, Data Port, USB Port and USB Cable

1. The power adapter is mainly to transfer the external power supply into the voltage and current required for the device operation.

⚠ Please use the power safely at the power connection part.

⚠ Please adopt an appropriate power adapter socket when using the device in other countries.

⚠ Do not block the power port or splash any liquid, shorten the circuit and touch the power port or placed in any metal, liquid, flammable gas and other items that may cause danger during the running

⚠ Please disconnect the power supply and put it at a safe place when the device is not used.

2. The data port is mainly for software updating and maintenance by the manufacturer.

⚠ Do not block, short the circuit or splash the liquid.

3. USB port and cable. The operator may connect the device via a USB cable to get the data of the user.

⚠ Do not block, short the circuit or splash the liquid.

## **2.4 Humidifier Function**

The humidifier is mainly to provide the user with the air of suitable temperature and humidity by heating the water in the water chamber. When using humidifier's function, it is suggested to use the tubing coming with the device to avoid air leakage. If you don't need the humidification function, you should turn off the humidifier. Please refer to 3.4 for how to turn on and off the humidifier.

⚠ For more humidifier information See Chapter 1.3

## **2.5 Power Outage Alarm**

During the running state, the exhaled air may be re-inhaled by the user in case of any power outage happens. To avoid this phenomenon, when power outage happened the system will provide a buzzing alarm and it will last for 30 seconds. During the alarm, press the ON/OFF button, or connect the device with power again, the alarm will stop. After connect the device with power, the system will enter into the normal working state.

## **2.6 Interface**

### **2.6.1 Main Interface and Sub-interface**

The device has 1 main interface and 5 sub-interfaces, as shown in Fig.2-1 to 2-8.



Fig.2-1 CPAP Main Interface



Fig.2-2 Auto CPAP Main Interface

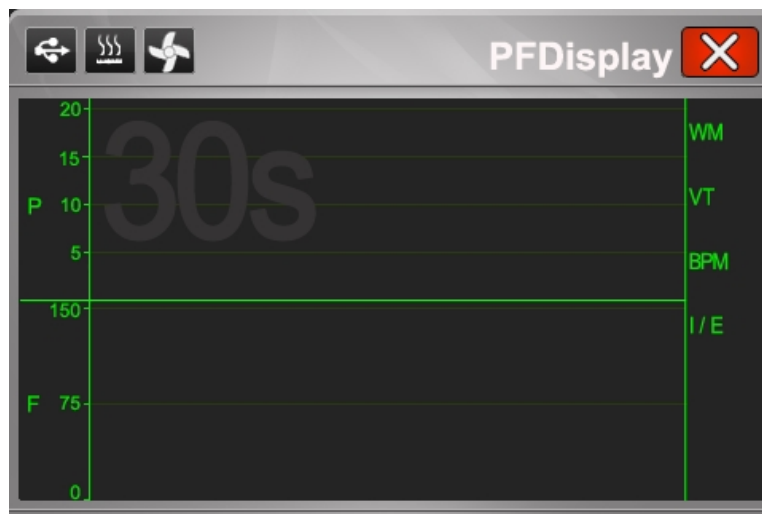

Fig.2-3 PFDisplay



Fig.2-4 CPAP Working Mode

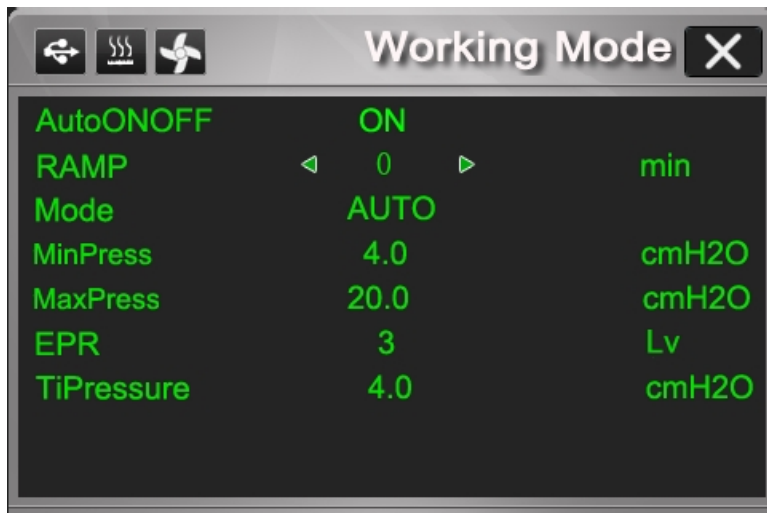

Fig.2-5 Auto CPAP Working Mode



Fig.2-6 Humidifier Setting Interface



Fig.2-7 System Setting

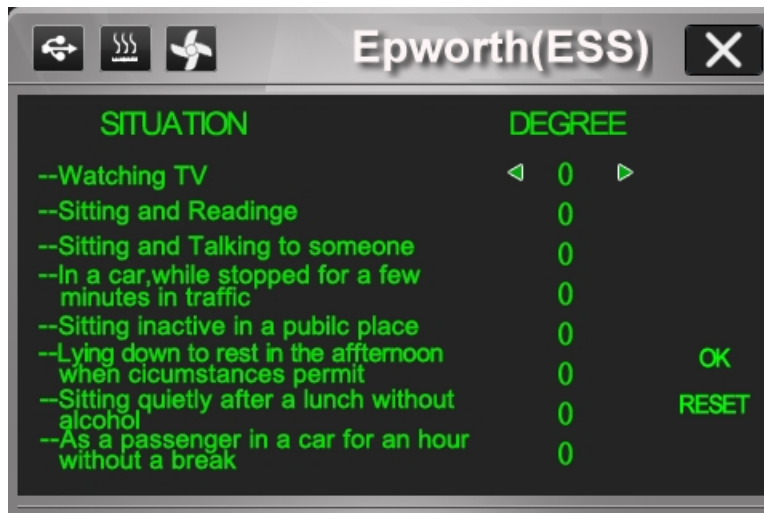







Fig.2-8 Epworth Testing Table

### 2.6.2 Interface Icon

The small icons on the interface as follows,

| Icon  | Description   |
|---|---|
|  | Indicating USB has been connected with the device   |
|  | Indicating that the humidifier is working   |
|  | Indicating the motor is working   |
|  | Indicating that the Ramp has been set   |
|  | Indicating that the parameter setting interface is locked, and some parameters can not be modified.In case of it go back to the main interface move cursor to the parameter setting icon, and press shuttle button until you hear a buzzing alarm |

### 2.6.3 Parameter Instruction

**Auto ON/OFF:** When the Auto ON/OFF is set to “ON”, user wears the mask and takes 3 breaths under the standby state, then the device will enter into working state; User takes off the mask under the working state, then within 15 seconds the device will enter into the standby state. When such function is set, the device will automatically enter into the standby state in case of the mask or tubing falls off during the sleep.

**RAMP:** Setting pressure ramp duration function. The device works at a 4cmH<sub>2</sub>O output pressure at the beginning and increase stably to the setting pressure within the setting time. After this function is set, pressing the on/off button for the first time the device will start running with ramp function; and with the second pressing, the device will jump the ramp function and run at the setting pressure directly. Please note the ramp function only works at the CPAP mode.

**Working mode:** There are 2 working modes CPAP & Auto

**CPAP:** The device outputs a constant pressure.

**Auto:** The device outputs a constant pressure automatically according to the breath of the user

**Pressure:** Under Mode CPAP, the device outputs the setting pressure

**Min P:** Under Mode AUTO, the minimum pressure the device can automatically adjust.

**Max P:** Under Mode AUTO, the maximum pressure the device can automatically adjust.

**EPR:** Setting the EPR function under the CPAP Mode, the device will automatically detect respiratory rhythm of the user and lower pressure in the mask during the expiration to make the user feel more comfortable.

**Humidifier:** Starting the heating and humidifying function

**Date and time of the system:** Internal clock of the device, according to which the machine records user's application information during operation, shall be checked frequently to ensure its correctness.

**Backlight:** The time of the LCD backlight will be on; the backlight will be off automatically when the set time is reached

**Therapy T:** Total use time of the device, and this time can be reset.

**Use Time:** Total use time. And this time can't be reset.

**Use Days:** The device is constantly running more than 4 hours defined as one

day. And this time can't be reset.

#### 2.6.4 Parameter Setting

Refer to 2.6.1, you can find the position of the parameter that you want to set.

E.g.: Modifying pressure 4cmH<sub>2</sub>O as 5cmH<sub>2</sub>O (if you are on the main interface ).

Rotate the shuttle flying clockwise once to move the cursor the parameter setting icon -> press the shuttle flying -> rotate the shuttle clockwise twice (the clockwise rotation increases pressure while the counterclockwise decreases pressure. The max pressure is 20cmH<sub>2</sub>O while the min pressure is 4cmH<sub>2</sub>O with a 0.5 cmH<sub>2</sub>O increment) -> press the shuttle flying (save and exit parameter settings).

E.g.: Setting the time 09:37:15 as 09:37:20 (if you are on the main interface ).

Rotate the shuttle flying clockwise three times to move the cursor to the system setting icon-> press the shuttle flying -> rotate the shuttle flying counterclockwise once -> press the shuttle flying -> rotate the shuttle flying twice to move the cursor to 15 -> press the shuttle flying and rotate the shuttle clockwise for five times -> press the shuttle flying and exit the edit mode.

#### Environmental Specifications

|                     | Working Environment          | Storage Environment          |
|---------------------|------------------------------|------------------------------|
| Temperature         | 5°C to 35°C                  | -20°C to 60°C                |
| Humidity            | 15% to 95% (no condensation) | 15% to 95% (no condensation) |
| Atmosphere pressure | 77 to 101kPa                 | Inapplicable                 |

#### Physical Specifications

|                |                   |
|----------------|-------------------|
| Dimension      | 255mm*170mm*112mm |
| Weight         | 1.8Kg             |
| Water capacity | MAX 200ml         |



### Parameter Scope

|              |  |
|--------------|--|
| Pressure     | 4~ 20cmH <sub>2</sub> O (±1cmH <sub>2</sub> O) with a 0.5cmH <sub>2</sub> O increment  |
| Min pressure | 4~ 20cmH <sub>2</sub> O (±1cmH <sub>2</sub> O) with a 0.5cmH <sub>2</sub> O increment  |
| Max pressure | 4~ 20cmH <sub>2</sub> O (±1cmH <sub>2</sub> O) with a 0.5cmH <sub>2</sub> O increment  |
| Ramp         | 0~60min  |
| EPR          | 0 level     Close EPR<br>1 level     setting pressure -2cmH <sub>2</sub> O<br>2 level     setting pressure -3cmH <sub>2</sub> O<br>3 level     setting pressure -4cmH <sub>2</sub> O |
| Humidifier   | 0 level     close the humidifier<br>1 level     45°C<br>2 level     50°C<br>3 level     55°C<br>4 level     60°C<br>5 level     65°C   |
| System time  | 24-hour  |
| Back Light   | 30seconds,60seconds,90seconds,120seconds,150seconds,240seconds,330seconds,420seconds,510seconds,600seconds   |

### Electrical Specifications

|  |  |
|--|--|
| Power adapter                                    | Model: DSS-240250 60VA<br>Input: 100-240V,50-60Hz<br>Output: +24V,2.5A   |
| Type of protection<br>Against Electric shock     | Class II Equipment   |
| Degree of Protection<br>Against Electric shock   | Type BF applied part   |
| Degree of Protection<br>Against Ingress of Water | IPX1   |
| Noise Level                                      | <30dB,when the device is working at the pressure of 10cmH <sub>2</sub> O |

## Humidifier

Doing the test according to YY 0786-2010 standard or equivalent methods.

|   |  |
|---|--|
| Output air flow temperature:            | <40°C  |
| Humidity scope:                         | 10-40mg/L  |
| Pressure drop caused by humidifier:     | <0.5cmH <sub>2</sub> O (with the flow rate of 60LPM) |
| Leaking under maximum working pressure: | <25mL/min (Together with the tubing)                 |
| Adaptability:                           | <20mL/kPa (Together with the tubing)                 |
| Preheating time:                        | 30 minutes   |

## Pressure Accuracy

According to the maximum dynamic pressure changes of ISO 17510-2007 standard.

| Pressure (cmH <sub>2</sub> O) | 10 BPM | 15 BPM | 20 BPM |
|-------------------------------|--------|--------|--------|
| 4                             | 0.21   | 0.5    | 0.71   |
| 8                             | 0.3    | 0.54   | 0.75   |
| 12                            | 0.39   | 0.58   | 0.85   |
| 16                            | 0.40   | 0.65   | 0.87   |
| 20                            | 0.40   | 0.70   | 0.97   |
| 25                            | 0.53   | 0.78   | 1.09   |

## Maximum Flow

According to the maximum flow of ISO 17510-2007 Standard

| Set pressure (cmH <sub>2</sub> O) | Measured pressure (cmH <sub>2</sub> O) | Maximum flow (L/min) |
|-----------------------------------|--|----------------------|
| 4                                 | 3                                      | 38.2                 |
| 8                                 | 7                                      | 38.6                 |
| 12                                | 12                                     | 39.5                 |
| 16                                | 16                                     | 41.1                 |
| 20                                | 19                                     | 41.9                 |
| 25                                | 24                                     | 44.1                 |

**Note:** The design of the device as a whole include the host and the humidifier, all test data were carried out under conditions with a humidifier.

## 3. Device Operation

### 3.1 Device Checking and Connection

When connecting the device, check it according to the following sequence before using it.

1. Check the power supply, if it is damaged or may cause the power leakage.
  2. Check the filter,if there is obvious dust on it,please replace it
  3. In case of any damage to the tubing, mask and headgear, or beyond its validity, please replace them immediately.
  4. If the water chamber cracks, leaks or deforms, please replace it.
  5. Check the power port, data port or USB port whether it is blocked or shorted.
  6. Check whether there is a shuttle flying cap.
  - 7.Check the host,if damaged it may cause the user inhaling the unfiltered air.
  8. Check whether there are foreign objects in the water chamber.
- Refer to the following figure for the connection method.

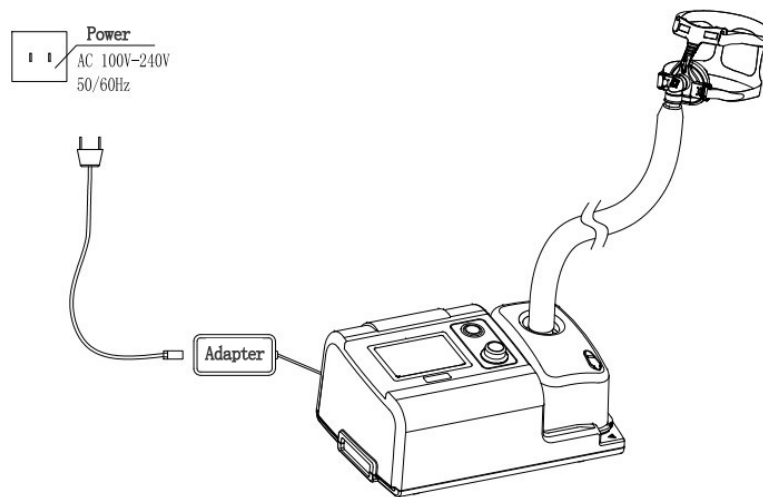

1. Push the water chamber into the host. Please refer to 3.2 for Water Chamber using.
  2. Connect the tubing to the water chamber outlet and the mask inlet.
  3. Put the filter into the host inlet.
  4. Plug the power adapter into the socket of the non-wall switch.
  5. Start up the device for more than 10 seconds to exclude the exhaust gas in the tubing and mask.
  6. Wear mask to start using the device.
- ⚠ Put the device on a solid and flat surface place where it is easy to approach but not easy to fall off and keep it lower than the sleep place.
  - ⚠ Ensure that the device inlet is not blocked by beddings, curtains or other objects.
  - ⚠ Ensure that the air surrounding the device can flow freely,so that the system

can provide better fresh air to the user.

△ Ensure that the device is far away from any heating or cooling equipment (such as mandatory vent, radiator and air conditioning, etc.).

△ Do not place the device directly on a carpet, fabrics or other flammable materials.

△ Do not place the device in or on a container where the water may retain.

△ Take preventive measures to avoid device damage due to water.

△ Do not start up the device before installing the water chamber.

△ Do not move the device when there is water in the water chamber, to avoid the water splashing into the host or the tubing.

### **3.2 Humidifier Setting**

1. Refer to 4.2 for Water Chamber Cleaning and Maintenance before use

2. If need a humid air,adding distilled or pure water into the water chamber

△ It is recommended adding suitable warm water in the winter. The water temperature should not exceed 35°C.

△ The water added should not exceed the maximum water level.

△ If water runs out during the working state,please turn off the humidifier or turn off the device and add water when the humidifier cools down to the room temperature. Do not add water when the humidifier is running.

△ Do not splash the water in the host when adding water.

3. It is recommended to directly push the water chamber into the host with the host facing up.

△ Please push in the water chamber completely to meet the host outlet.

△ Do not touch the heater plate.

△ Do not tilt the water chamber.

### **3.3 Turn on/off Device**

Press the on/off button to start up the device after properly installing the device.

Press the on/off button to turn off the device in the operation.

△ Please refer to 3.1 and 3.2 before starting up the device.

△ Please disconnect the power supply after turning off the device.

△ Turn off the device, uninstall the water chamber and empty the water in the water chamber.

## **4. Routine Maintenance**

## 4.1 Host Cleaning

1. Disconnect power supply of the device
2. Immerse a cloth with clean water or neutral detergent to wipe the front panel and the outer shell.
3. Dry the device.

 Please avoid the liquid flowing into the device during cleaning.

## 4.2 Water Chamber Cleaning

1. Disconnect power supply of the device.
2. Remove the water chamber.
3. Empty the water in the water chamber if any.
4. Clean the water chamber with detergent or neutral detergent.
5. Rinse it with clean water.
6. Dry it.

Please clean it at least once per day if it is used often.

 If the water chamber cracks, leaks or deforms, please replace it.

 Empty the water in the water chamber everyday to prevent breeding mold and bacteria into water chamber

## 4.3 Tubing Cleaning

1. Disconnect power supply of the device
2. Disconnect the tubing from the water chamber and mask.
3. Clean the tubing with the detergent or neutral detergent gently.
4. Rinse it with water.
5. Dry it.

 Replace the tubing immediately if it is damaged.



## 4.4 Mask Cleaning

1. Clean the mask carefully with the neutral detergent, especially the silicon pad close the skin.
2. Rinse all the components with the water.
3. Dry it with the soft cloth.

 Do not place it under the directly sunshine or on the central heating.

## 4.5 Filter Cleaning

Filter is an item used for a short time, which should be one to two weeks.

-  Please replace the filter if it is damaged.
-  It is prohibited installing a wet filter into the host.
-  The filter must be installed before running the device.

## 4.6 Disinfection

Generally, if you follow the cleaning instruction correctly, you do not have to sterilize the device and its components. When water chamber and other components are contaminated or used for the clinic, the standard sanitizer get from pharmacist can be used to do the sterilizing.

 Please note that sanitizer will damage the material surface and shorten their service life. Therefore, you shall follow suggestions given by sanitizer supplier on the applicable specific material and application instruction.

 At last, using water to completely clean the components which have close contact with patient, such as mask, headgear and tubing, etc., to prevent skin and respiratory tract infection caused by residual solution.

## 4.7 Transferring to another patient

 If device is to be delivered to another patient, for sanitation purpose, the component which have close contact with this patient, such as mask, headgear, tubing and filter shall be replaced with new ones. Or referring to the description in 4.6 “Disinfection”

## 5. Troubleshooting

| Phenomenon   | Possible cause analysis                               | Troubleshooting   |
|--|---|---|
| Nothing displayed on the screen or it does not enter the main interface after it is turned on. | The power supply of the device is not well connected. | Disconnect the power plug and re-connect the power supply correctly |
| There is a beep alarm after it is turned on.   | The power supply of the device is not well connected. | Disconnect the power plug and re-connect the power supply correctly |
| The device fails to stop automatically after the remove the mask                               | The option of “Auto on/off” is closed.                | Set the option of “Auto on/off” as “On”                             |

|  |  |   |
|--|--|---|
| Nose and throat are dry with irritation symptoms   | Dry air  | Increase the temperature of the humidifier or consult the doctor.   |
| The nose gets cold   | The room temperature is low  | Increase the room temperature   |
| Oral cavity and throat get dry   | breathing with an open mouth<br>The pressure set is too low  | Please consult the doctor.  |
| Eyes are irritated or dry.   | The mask leaks or the size of the mask is not suitable.  | Adjust the mask and its headgear, consult the doctor whether should be replaced. Please replace the mask beyond its validity. Try other size mask.    |
| Face gets inflamed   | The headgear is too tight.<br>The mask size is not suitable.<br>Allergic to the mask material  | Adjust the headgear properly<br>Consult the doctor<br>Consult the doctor  |
| There is water in the mask   | The room temperature is too low, resulting in the water condensation in the mask.  | Reduce the temperature of the humidifier or increase the room temperature. Cover the tubing with a towel or similar heat preservation soft cloth      |
| The device has a high pressure that has not been set or the pressure fluctuation is too large. | Pressure sampling tubing is blocked or there is water in it.<br>Pressure sampling tubing is not connected with the host                              | Dry the pressure sampling tubing completely or remove the block<br>Connect the pressure sampling tubing with the host                                 |
| The nose, paranasal sinus or ear hurts   | Inflammation   | Stop using and consult the doctor   |
| OSAHS relapse (e.g.: drowsiness in daytime)  | The treatment pressure that you require may be changed due to your weight, nasal obstruction, drinking or other reasons.                             | Consult the doctor  |
| The temperature of the air inhaled is too high   | The inlet is blocked by the dirty filter.<br>The device is too close to the wall, curtain or other objects, resulting in the non-smoothness air flow | Replace the filter<br>Check the air inlet<br>Move the device to a place with a smooth air flow, at least 20cm from the wall, curtain or other objects |
| No airflow output  | Device fault<br>There is water in the sampling pressure tubing   | Contact with the manufacturer<br>Dry the sampling pressure tubing   |
| The output air flow is too small.  | The air inlet is blocked under Ramp working state  | Shorten the time of Ramp<br>Check the air inlet   |
| The blower is at a high speed always   | Pressure sampling tubing is not connected or blocked<br>The device leaks.  | Inspect the pressure sampling tubing<br>Contact the manufacturer for maintenance  |
| The device is not working after turn on  | The device has failure.  | Contact with the manufacturer   |
| The device is working while the mask pressure is obviously different with the setting pressure | The tubing leaks.<br>Sampling pressure tubing is connected incorrectly or blocked.   | Ensure the tubing is correctly connected<br>Contact the manufacturer for maintenance  |
| The device can only generate low pressure.   | The air inlet is blocked<br>The treatment pressure has   | Replace the filter, clean the inlet   |

|                            |   |  |
|----------------------------|---|--|
|                            | been re-adjusted.<br>The Ramp is set  | Consult with the doctor<br>If necessary, you may cancel the Ramp or reset the Ramp time. |
| The device is too noisy    | The tubing is not connected or is not connected correctly.<br>The mask or the tubing leaks. | Ensure the connection is correct.<br>Ensure there is not leakage of the tubing and mask  |
| The pressure cannot be set | In a Ramp state   | Please exit from the Ramp state and re-set it.   |
| Ramp cannot be set         | In a Ramp state   | Please exit from the Ramp state and re-set it.   |

## 6. Waste Disposal

Except for designated specifically the device components and packaging boxes , please follow the following instruction: Please dispose them according to relevant national laws and regulation.

## 7. Warranty

From the date of purchase, we provide a one year warranty for the host, 3 months warranty for the tubing, mask and humidifier.

We,the manufacturer do not undertake the losses caused due to user misuse, abuse or accidents.

Device damage due to the water by user's misuse is not covered under warranty.

Disassembling the host without the manufacture's permission is deemed to give up the warranty.

## 8. Packing List

Host ×1, water chamber ×1, power adapter ×1, filter ×2, tubing ×1, mask ×1, instructions ×1, traveling bag ×1.



## 9. EMC Requirements

**Guidance and manufacturer's declaration** - electromagnetic emissions– this device is intended for use in the electromagnetic environment specified below.

| Emissions Test  | Compliance | Electromagnetic environment-guidance   |
|---|------------|--|
| RF emissions<br>CISPR11                                   | Group 1    | The internal function of the device only use the RF energy. Therefore its RF emissions is very low and are not likely to cause any interference in nearby electronic equipment.  |
| RF emissions<br>CISPR11                                   | Class B    | This device is suitable for use in all establishments including domestic establishments and those directly connected to the public low-voltage power supply network that supplies buildings used for domestic purposes |
| Harmonic emissions<br>IEC61000-3-2                        | Class A    |  |
| Voltage fluctuation<br>/flicker emissions<br>IEC61000-3-3 | Conformity |  |

**Guidance and manufacturer's declaration** - electromagnetic immunity – this device is intended for use in the electromagnetic environment specified below. The user of the device should make sure that it is used in such an environment.

| Immunity test  | IEC60601 test level   | Compliance level  | Electromagnetic environment-guidance   |
|--|---|---|--|
| Electrostatic discharge (ESD)<br>IEC61000-4-2  | ±6KV contact<br>±8KV air  | ±6KV contact<br>±8KV air  | Floor should be wood, concrete or ceramic tile. If floors are covered with synthetic material, the relative humidity should be at least 30%.   |
| Electrical fast transient /pulse<br>IEC61000-4-4   | ±2KV for power line<br>±1KV for input/output line   | ±2KV for Main power line<br>±1KV for input/output lines   | Mains power supply should be typical home or hospital power supply   |
| Surge<br>IEC61000-4-5  | ±1K differential mode<br>±2KV common mode   | ±1KV differential mode<br>±2KV common mode  | Mains power should be typical home or hospital power supply  |
| Voltage dips, short interruptions and voltage variations of the input power<br>IEC61000-4-11 | <5% $U_T$<br>(>95% dip in $U_T$ ),<br>for 0.5 cycle<br><br>40% $U_T$<br>(60% dip in $U_T$ ),<br>for 5 cycles<br><br>70% $U_T$<br>(30% dip in $U_T$ )<br>for 25 cycles<br><br><5% $U_T$<br>(>95% dip in $U_T$ )<br>for 5 s | <5% $U_T$<br>(>95% dip in $U_T$ ),<br>for 0.5 cycle<br><br>40% $U_T$<br>(60% dip in $U_T$ ),<br>for 5 cycles<br><br>70% $U_T$<br>(30% dip in $U_T$ )<br>for 25 cycles<br><br><5% $U_T$<br>(>95% dip in $U_T$ )<br>for 5 s | Mains power should be typical home or hospital power supply<br>If the main supply interrupt, it is recommended to choose a uninterruptible power supply or the battery to support the device |
| Power frequency (50/60Hz) magnetic field<br>IEC61000-4-8                                     | 3A/m  | 3A/m  | Power frequency magnetic field shall be typical level of power frequency magnetic fields in hospital or home environment.  |
| Note: $U_T$ is the AC mains voltage prior to application of the test level.                  |   |   |  |

**Guidance and manufacturer's declaration** - electromagnetic immunity – this device is intended for use in the electromagnetic environment specified below. The user of the device should make sure that it is used in such an environment.

| Immunity test   | IEC60601 test level  | Compliance level         | Electromagnetic environment-guidance  |
|---|--|--------------------------|---|
| <p>Conducted RF<br/>IEC61000-4-6</p> <p>Radiated RF<br/>IEC61000-4-3</p>  | <p>3Vrms<br/>150kHz to<br/>80MHz</p> <p>3V/m<br/>80MHz to<br/>2.5GHz</p> | <p>3Vrms</p> <p>3V/m</p> | <p>Portable and mobile RF communications equipment should be not less than the recommended distance to any part of the device, including cables, which is calculated from the equation application to the frequency of the transmitter.</p> <p>Recommended separation distance<br/> <math>d=1.2 \sqrt{p}</math><br/> <math>d=1.2 \sqrt{p}</math>      80MHz to 800MHz<br/> <math>d=2.3 \sqrt{p}</math>      800MHz to 2.5GHz</p> <p><math>\sqrt{p}</math> is the maximum normal output power of the transmitter, its unit is Watt (W) and <math>d</math> is the recommended separation distance, its unit is meter (m).</p> <p>Measured magnetic field strengths <sup>a</sup> from fixed RF transmitter should be less than the compliance level in each frequency range <sup>b</sup></p> <p>Interference may occur in the vicinity of equipment marked with the following symbol: </p> |
| <p>Note 1: At 80 MHz and 800 MHz, the higher frequency range applied.</p> <p>Note 2: These guidelines may not be apply in all situations. Electromagnetic propagation is affected by absorption and reflection of the building , objects and human body.</p> <p>a. Magnetic Field strengths from fixed transmitters, such as base stations for radio (cellular / cordless) telephones and land mobile radios, amateur radio, AM and FM radio broadcast and TV broadcast cannot be predicted theoretically with accuracy. To assess the electromagnetic environment of the fixed RF transmitters, an electromagnetic site survey should be considered. If the measured magnetic field strength in the location in which the device is used exceeds the applicable RF compliance level above, check the device whether it can under normal operation. If abnormal performance is observed , additional measures should be taken.</p> <p>b. The field strengths should be less than 3 V/m, when the frequency range is from 150kHz to 80MHz.</p> |  |                          |   |

**Version No.: Auto CPAP/20140526/002**